

TF1 OMEGA FILTER

Designed for installation in small or restricted access areas, this high performance, easy to clean system filter uses Hydronic Particle Separation and magnetic filtration to remove contaminants from central heating system water.

- High capacity and compact design
- Ideal for use in restricted spaces and access areas
- Easy to install – fits on horizontal and vertical pipework in both flow directions. The filter can operate at an angle of 45°
- Fast and easy to clean without dismantling the unit
- Unique action, removes magnetic and non-magnetic contaminants from system water
- Easy to fit slip socket with compression fitting and short pipe cut-out length
- Will not block or restrict flow
- Smart, tough, forged brass construction (no hidden porosity) with nickel plating
- Unique manifold with double radial seals and multiple orientation capability
- Powerful neodymium magnet assembly with threaded magnet cap
- As with all magnetic products, if you have an implanted cardiac device extra caution should be taken at all times when handling any magnetic filter
- Available as 22mm and 28mm products

Product Specifications

- | | |
|----------------------------------|--|
| ■ Maximum operating temperature: | 100°C |
| ■ Maximum operating pressure: | 10 bar |
| ■ Maximum flow rate: | 50 L/min |
| ■ Magnetic characteristics: | Powerful neodymium magnetic assembly |
| ■ Drain valve characteristics: | Easy to install with multiple orientation capability |
| ■ Filter material: | Tough, forged brass construction with nickel plating.
Compatible with EN 12165-CW617N-M |

Weight

TF1 Omega Filter 22mm	1615g (with magnet and drain valve)
TF1 Omega Filter 28mm	1695g (with magnet and drain valve)



TF1 Omega Filter 22mm

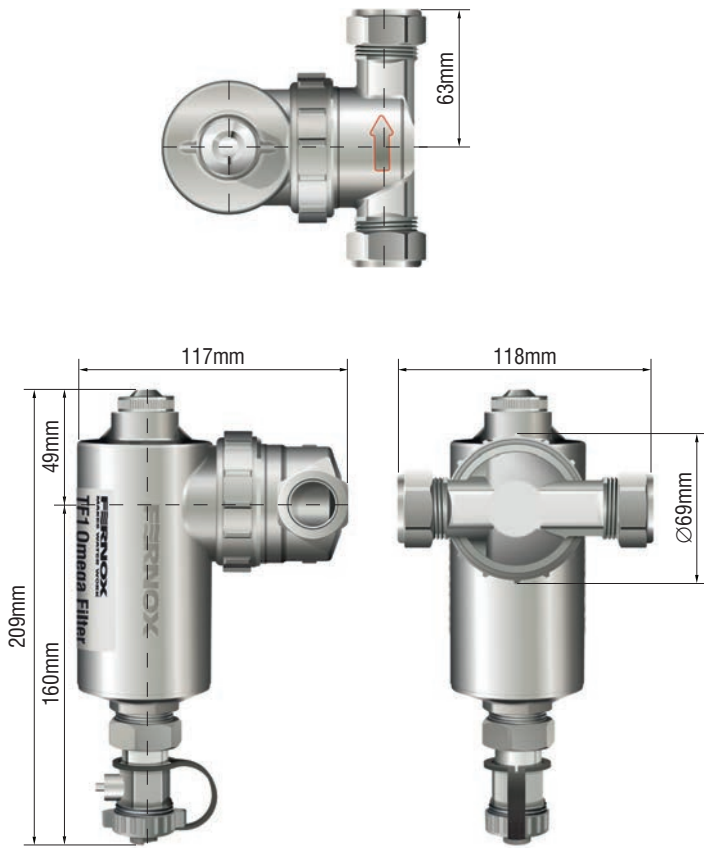

TF1 Omega Filter 28mm

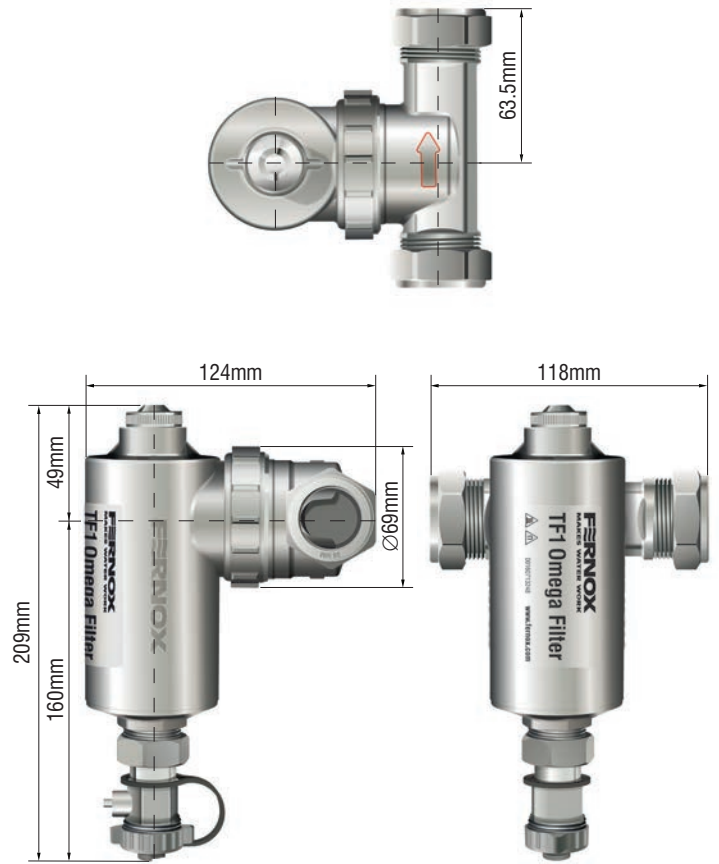

Cleaning Guide

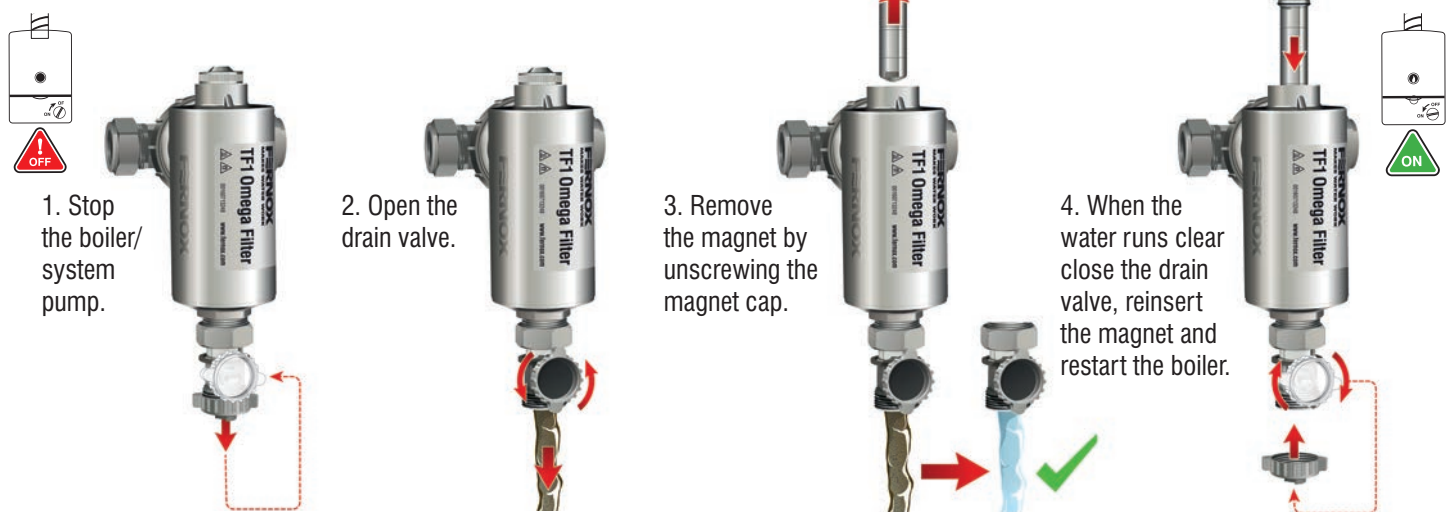

Ensure that the magnet sheath remains clean and dry.

Dosing Guide

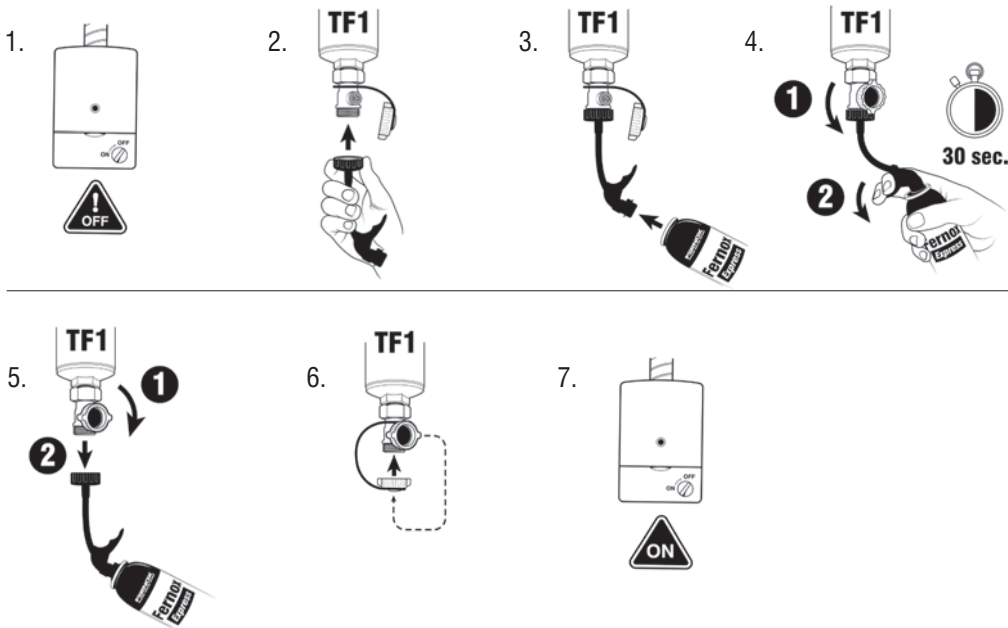

Easy dosing of FernoX Express products via a TF1 Filter with a slip socket connection.

Note: If the filter contains magnetite or sludge, flush it clean with water before dosing. Refer to the cleaning guide instructions.

Caution: Hot surface.

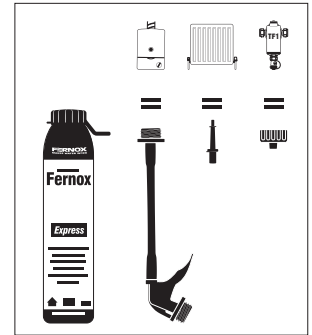

Pressure Loss Data

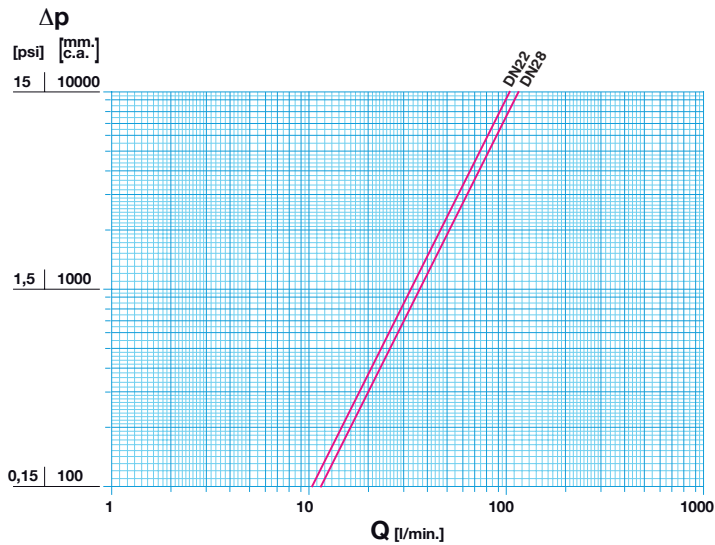

Application

Designed to be installed close to the wall, the filter can be easily fitted into either horizontal or vertical pipework in both flow directions.

Inhibitor usage guidelines

A TF1 Omega Filter will protect the boiler from the damaging effects of circulating corrosion debris, which has collected in the system as a result of a chemical reaction when water comes into contact with mixed metals used within a heating and cooling system. Note: to prevent further corrosion from taking place a quality inhibitor should be used in combination with the TF1 Omega Filter. In circumstances where demineralised or softened water is present a quality inhibitor must be used.

Product Codes

TF1 Omega Filter 22mm – 62248 TF1 Omega Filter 28mm – 62251 TF1 Omega Filter Flushing Adapter – 62289



Packaging, Handling and Storage

Individually packaged with instructions included. No special storage requirements.

Spare parts available from FernoX: Tel: +44 (0) 330 100 7750 Email: sales@fernox.com